

High-performance 3D AOI made simpler and faster

Mycronic inspection solutions MYPro I™ series 3D AOI





Actual image from
Iris™ 3D vision.

MYPro I series 3D AOI

Put your inspection on autopilot

At Mycronic, we're on a mission to enable tomorrow's zero-defect SMT line. The new MYPro I series 3D AOI brings your factory one step closer to this vision by continually improving product quality and first-pass yield with minimal operator intervention.

THE EVOLUTION CONTINUES

From automotive to aerospace electronics assembly, the K series 3D AOI has long been recognized for its high accuracy and repeatability. Thanks to its advanced algorithmic technology, it excels at processing all types of PCBs, making it one of the preferred 3D AOI systems among tier-one mid-volume EMSs in high reliability industries worldwide.

POWERFUL AOI FOR ANY ENVIRONMENT

The new MYPro I series 3D AOI brings these powerful capabilities to an even wider range of manufacturers, pushing the boundaries of ergonomics and automation to the forefront of the industry. Designed for enhanced user experience, it offers intuitive programming guidance and self-optimizing process controls, ensuring easy implementation of high-performance AOI for any operator in any production mix or class.

By combining industry-leading performance with a highly intuitive, user-centric architecture, the MYPro I series is a game changer.

MYPro I series 3D AOI

World-class inspection starts with outstanding image acquisition

In the world of high-reliability electronics, the pace of change continues to accelerate. To handle even the most advanced assemblies with any size of components, the MYPro I series offers you an industry-renowned 3D scanning technology with outstanding reliability, accuracy and flexibility.

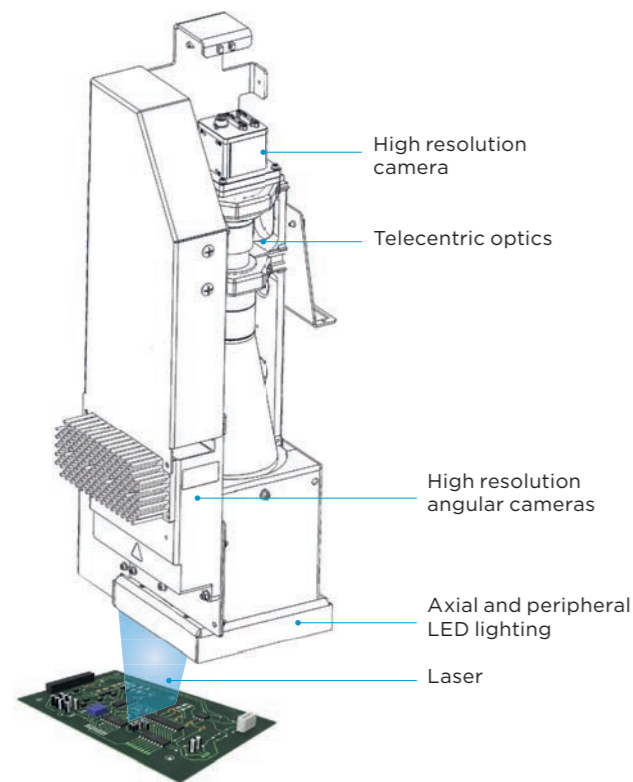

HIGH-RESOLUTION CAMERA with fully telecentric lens captures high-quality RGB images for inspection and review.

HIGH-PERFORMANCE 3D SENSOR combines vertical laser and angled cameras to avoid projection shadows, optimized angles to minimize intrinsic shadow effects and adaptive height filtering that adapts the sensor's sensitivity to component geometry.

SOPHISTICATED CONCEPTION

- High-precision motion system with 0.1 μm accuracy
- +/- 5 mm warpage compensation
- Constant Z resolution of 1 μm from -5 to +20 mm
- Vectoral imaging pattern matching.



NEXT-GENERATION IRIS™ 3D VISION TECHNOLOGY - DESIGNED FOR THE MOST DEMANDING TAKT TIMES

Thanks to a new generation of laser-based 3D sensor, optics and computing systems, Iris enables the industry's highest quality 2D and 3D image capture at speeds up to 30% faster than K3D technology. All so you can capture every detail in unprecedented resolution even at the most demanding takt times.

	K3D	Iris™
Resolution - sub-pixel technology	4.75 μm	3.45 μm
Min. inspectable package size	001005 / 0402 metric	008004 / 0201 metric
Compatibility	MYPro I50 MYPro I90	MYPro I51 MYPro I81 MYPro I91

Powered by AI to bring performance and usability to new heights

As production conditions change and grow more complex, 3D AOI inspection is increasingly critical to eliminating defects, waste and rework. Thanks to a new software utilizing AI image classification and pattern recognition, the MYPro I series makes implementation easier than ever. Whatever size your production batches, and however experienced your operators may be, these advanced automation features continually maintain the highest levels of inspection performance.

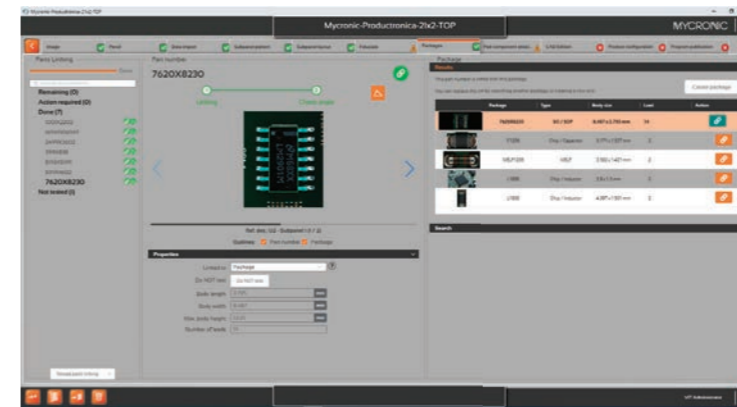

For every new part number, MYPro Link automatically detects component body and leads, and finds corresponding package in the central library.

MYWIZARD: UP TO 30% FASTER PROGRAMMING

The new MYWizard user interface integrates two artificial intelligence systems—Parts Linking, an advanced component recognition technology, and new machine learning algorithms that locate fiducials and component's polarity—in order to guide operators through the programming faster. It results in up to 30% reduction in programming time compared with previous generations, with reduced operator experience and training.

ESCAPE TRACKER FOR AUTOMATED PERFORMANCE OPTIMIZATION

MYPro I series features a next-generation self-checking inspection performance system. With Escape Tracker, the user is immediately informed of any errors or programming weaknesses that could potentially generate false calls or escapes. Central library items that need to be corrected are clearly displayed allowing for easier, faster and safer fine-tuning.

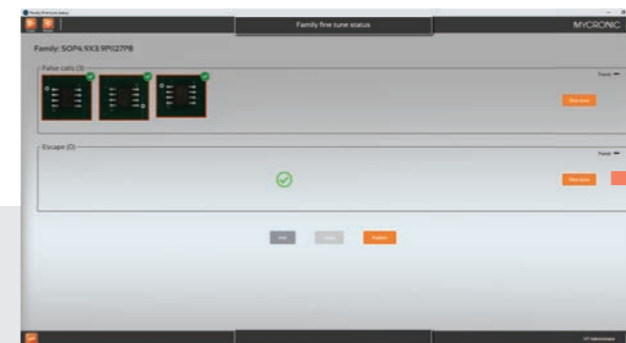

During programming process, Escape Tracker alerts on three potential false calls.

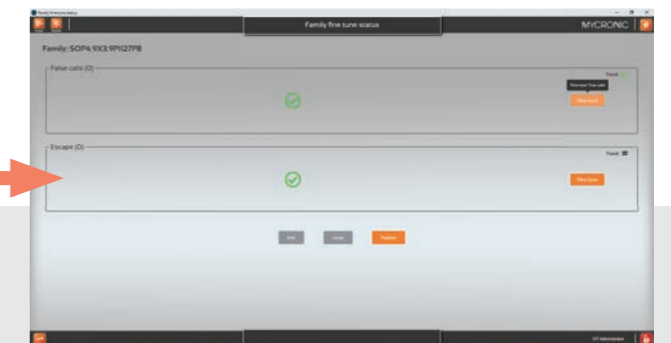

After fine-tuning, Escape Tracker confirms false calls are eradicated, and no escapes are introduced.

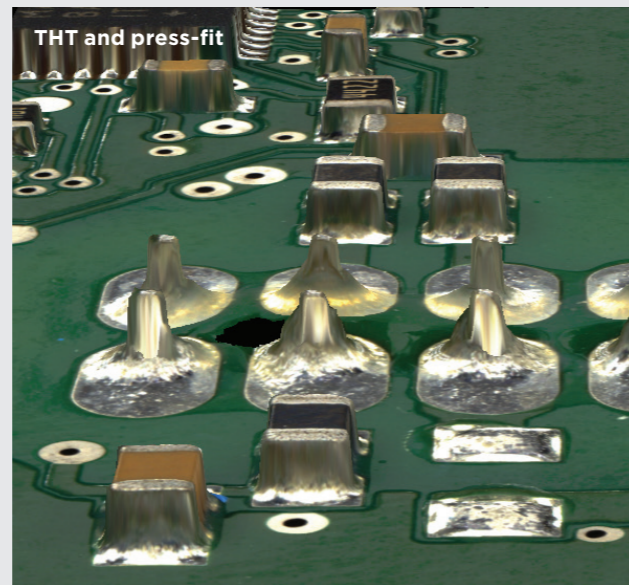
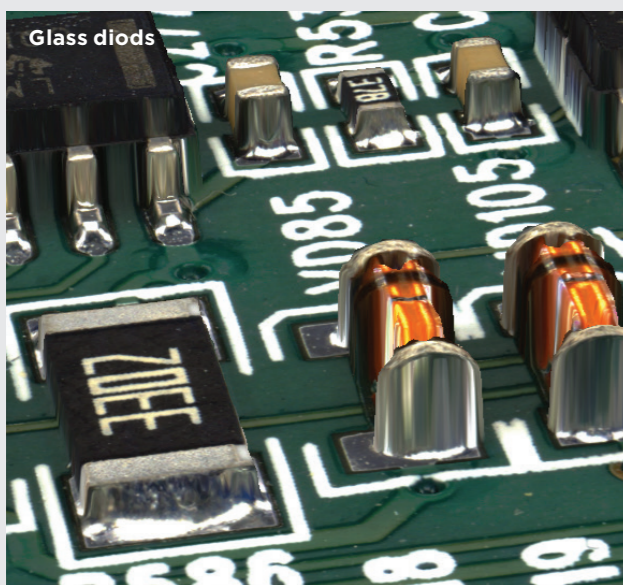
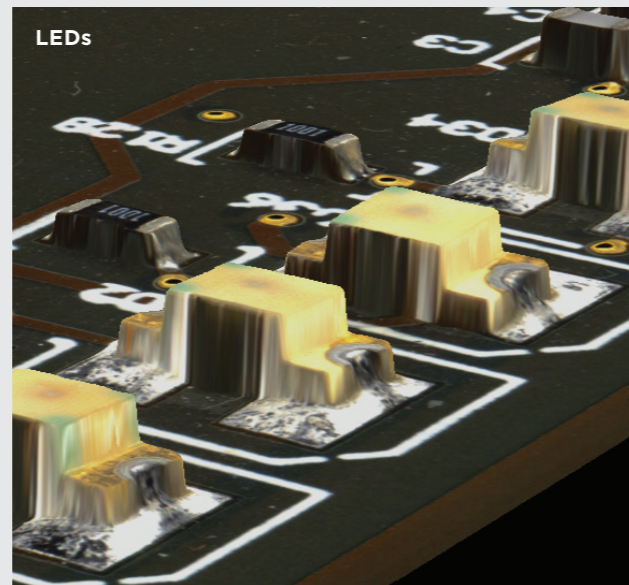
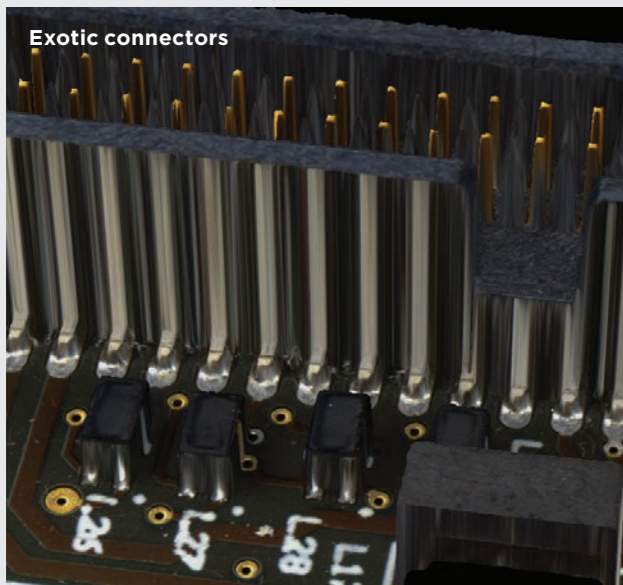
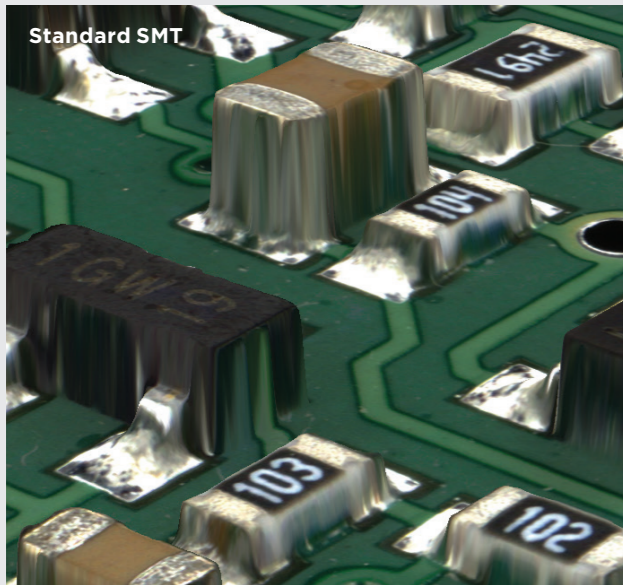

Superior accuracy for any product geometry

The MYPro I series offers best-in-class accuracy and repeatability in X, Y, Z and Theta for efficient process control. The unique combination of sub-pixel geometric pattern matching technology, proprietary 3D algorithms and unique warpage and distortion compensation leads to superior critical measurement capabilities.

All-in-one inspection capabilities

The MYPro I series expands defect coverage using a combination of 2D imaging and shadow-free 3D inspection enabled by state-of-the-art cameras, 3D sensor and motion system technologies.

In addition to a comprehensive SMT test coverage, the MYPro I series offers advanced inspection capabilities for top and bottom THT and press-fit components, and an Automated Optical Metrology (AOM) feature for high-precision distance, coordinate, and angle measurement.

COMPLETE TEST COVERAGE

Comprehensive defect coverage accurately measures component body and solder joints to identify misplaced components, tombstones, lifted leads and more.

ALL-COMPONENT INSPECTION

Comprehensive toolbox of ready-to-use 2D and 3D tests to inspect any SMT components, but also through-hole or press-fit components, connectors of any type and shape, as well as novel

components. The geometry and relative positions of components, pins, or connectors can also be inspected to further expand your test coverage.

Results at a glance with **MYPro Review**

MYPro Review gives operators an easy way to make pass/fail diagnoses at a glance. By automatically correlating SPI and AOI results into a single on-screen overview, it not only provides a highly accurate and simplified defect classification system, but also helps fine-tuning SPI tolerances for optimal first-pass yield.



- Review high-quality 3D defect images to localize defects at a glance
- Easy classification using reference images
- Use IPC or user-defined defect categories
- Speed up reaction times with pre-defined corrective action messages
- Optimize review environment with customized screen layouts

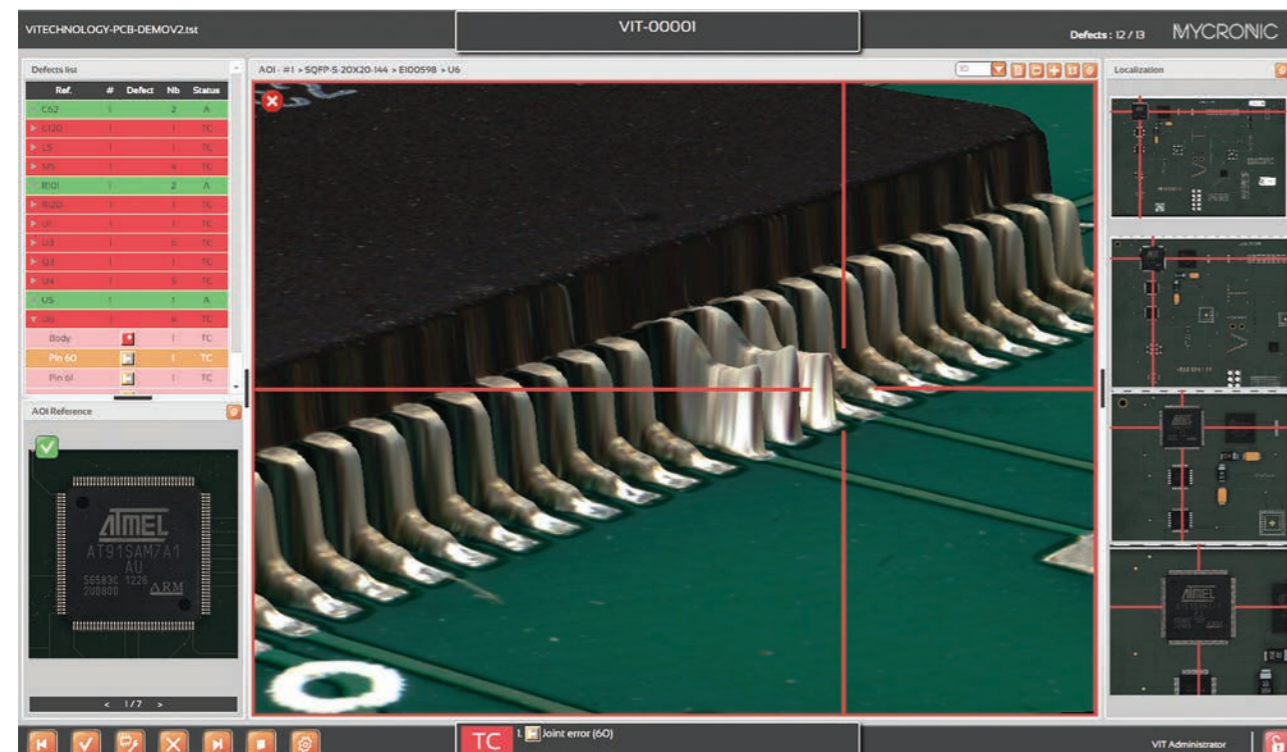

High viewing comfort, for greater efficiency of review operations.

Industry-leading performance and **production stability**

Today's lean and agile manufacturing calls for superior first pass yield efficiency and 100% performance portability from one line to another. MYPro I series satisfies the most demanding customers in the electronics assembly industry where quality and productivity are both mission- and business-critical. The system has been designed to optimize test coverage at line speed for the smart factory while offering 100% offline capabilities.

Superior uptime above 99.5%.

Unified software suite for pre-reflow, post-reflow and post-wave AOI applications.

100% offline programming and tuning capabilities.

Full machine-to-machine portability for all programs.

Fully integrated **process control**

MYPro Link, Mycronic's award-winning web-based process control software suite, puts the benefits of inspection data correlation into real-time production. All so you can monitor your line performance over time or at a glance, and get to the root cause of every defect in just a few clicks.

Unified source of SPI and AOI data with MYPro Link, allowing you to view your process in real time, quickly drill down to the defect image and take immediate corrective action.

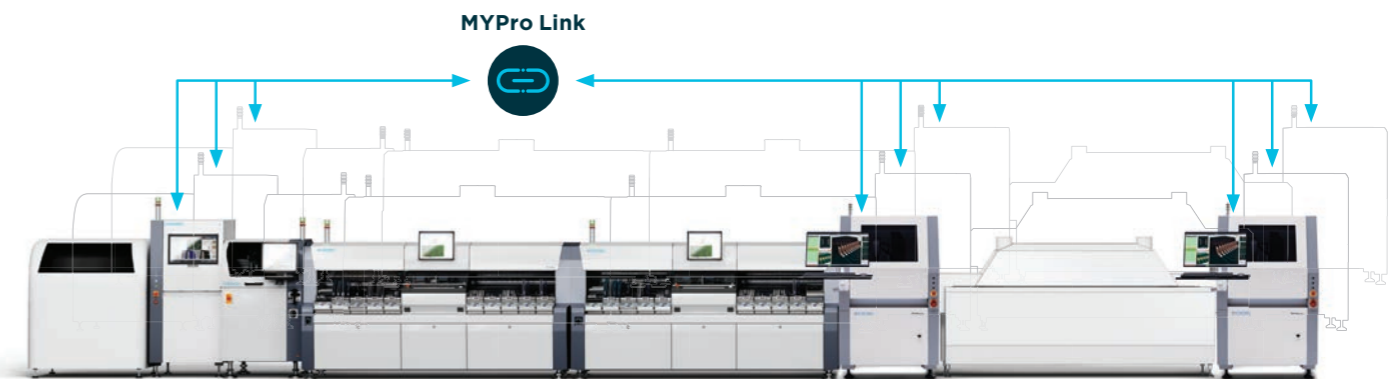

A complete range of 3D AOI to fulfill all your needs

	MYPro I50 / I90	MYPro I51 / I81 / I91
INSPECTION TECHNOLOGY		
Image acquisition system	K3D	Iris™ 3D vision technology
Optics	High-precision telecentric lens	
Field of View (X x Y)	61.1x44.9mm (2.40x1.76")	60.5x60.5mm (2.38x2.38")
Lighting types	Axial and peripheral LED with holographic diffuser	
Lighting colors	White, red, blue	White
Warp compensation	±5mm warpage compensation with full Z accuracy	

INSPECTION PERFORMANCE		
Defect types	Component body, Missing component, Misplacement (X, Y, Z, θ), Tombstone, Polarity, Coplanarity, Upside-down component, OCR/OCV, Solder joint, Missing joint, Solder excess, Bridging, Lifted lead, Head-in-pillow	
Metrology	Critical distance measurement capability with 10µm precision	
Foreign material detection	Embedded in standard software version	
Height inspection range	From -5mm to +20mm	
X, Y resolution	4.75µm with subpixel technology - 19µm native	3.45µm with subpixel technology - 13.7µm native
Z resolution	Constant resolution of 1µm over a 25mm range in Z	

SOFTWARE SUITE	
Vision integrated software suite	MYWizard or Vision3D
Vision offline programming	Available as an option
Vision library	Standard, based on JEDEC packages
Auto programming assistance	AI-powered algorithms for automatic association of new part numbers and for creation of new packages: - Auto-MatchMaker on Vision3D - Parts Linking on MYWizard
Library quality control	- Library Pro on Vision3D - Escape Tracker on MYWizard
Metrology software	Macro Tool

SYSTEM	
Operating system	Windows 10, 64-bit
PCB positioning	Board and panel fiducials
Axis motion	Linear motors with optical encoders—1µm repeatability

OPTIONS	
External barcode readers (1D/2D)	Cognex DM150 or Keyence SR1000W—also compatible with major barcode reader brands
Internal barcode readers (1D/2D)	Software option enabling reading from scanning head
Uninterruptible power supply	For PC 230V
115V power supply	Single phase 115V/60Hz/16A
Offline program preparation software	Offline programming software, including MYPro Create for SPI and AOI program creation, and MYPro Optimize for AOI library optimization
Offline review software	MYPro Review
Online SPC	MYPro Analyze
Other options available	Please contact us

The MYPro I series 3D AOI system is available in several versions to cover all SMT inspection needs: single lane, dual lane, and heavy duty. Field upgrades are also available.

	MYPro I50 / I90	MYPro I51 / I81 / I91
FACILITIES		
Interface	IPC-SMEMA-9851 (standard); HERMES (optional)	
Power requirements	Single phase 230V - 50Hz - 10A	
Dimensions in mm (W x D x H)	1,110 x 1,351 x (1,975-2,075)	
Weight	900kg	
Operating temperature	15°C-30°C	
Relative humidity	20-75% (without condensing)	
Network	TCP/IP, RJ45 plug	
Laser	Class-1 laser product according to the IEC 60825-1 standard	Class-2 laser product according to the IEC 60825-1 standard

	MYPro I50 / I51	MYPro I81	MYPro I90 / I91
PCB HANDLING			
Minimum PCB dimensions	51x51mm - 2x2"		
Maximum PCB dimensions (X x Y)	533x609mm 21x24"	Scan X mode <i>Single lane:</i> 533x600mm 21x23.6" <i>Dual lane:</i> 2 x (533x280mm) 2 x (21x11") Scan Y mode <i>Single lane:</i> 391x600mm 19.4x23.6" <i>Dual lane:</i> 2 x (391x325mm) 2 x (19.4x12.8")	533x609mm 21x24"
PCB thickness	0.5-4mm	0.5-4mm	0.5-15mm
Maximum PCB weight	3kg	3kg	15kg
Minimum edge clearance	3mm	3mm	Standard: 4 mm Option: 3 mm
Top clearance	34mm / 40mm	40mm	34mm / 40mm
Bottom clearance	60mm		
Conveying height	Standard: from 860 to 960 mm Option: up to 1,060 mm		

DIMENSIONS MYPRO I SERIES [mm]

